

鉗工銼 ENGINEER'S FILES

鉗工銼

011

扁
HAND

012

半圓
HALF ROUND

013

圓
ROUND

014

方
SQUARE

015

三角
TRIANGULAR

018

橢圓
OVAL

017

尖扁
FLAT

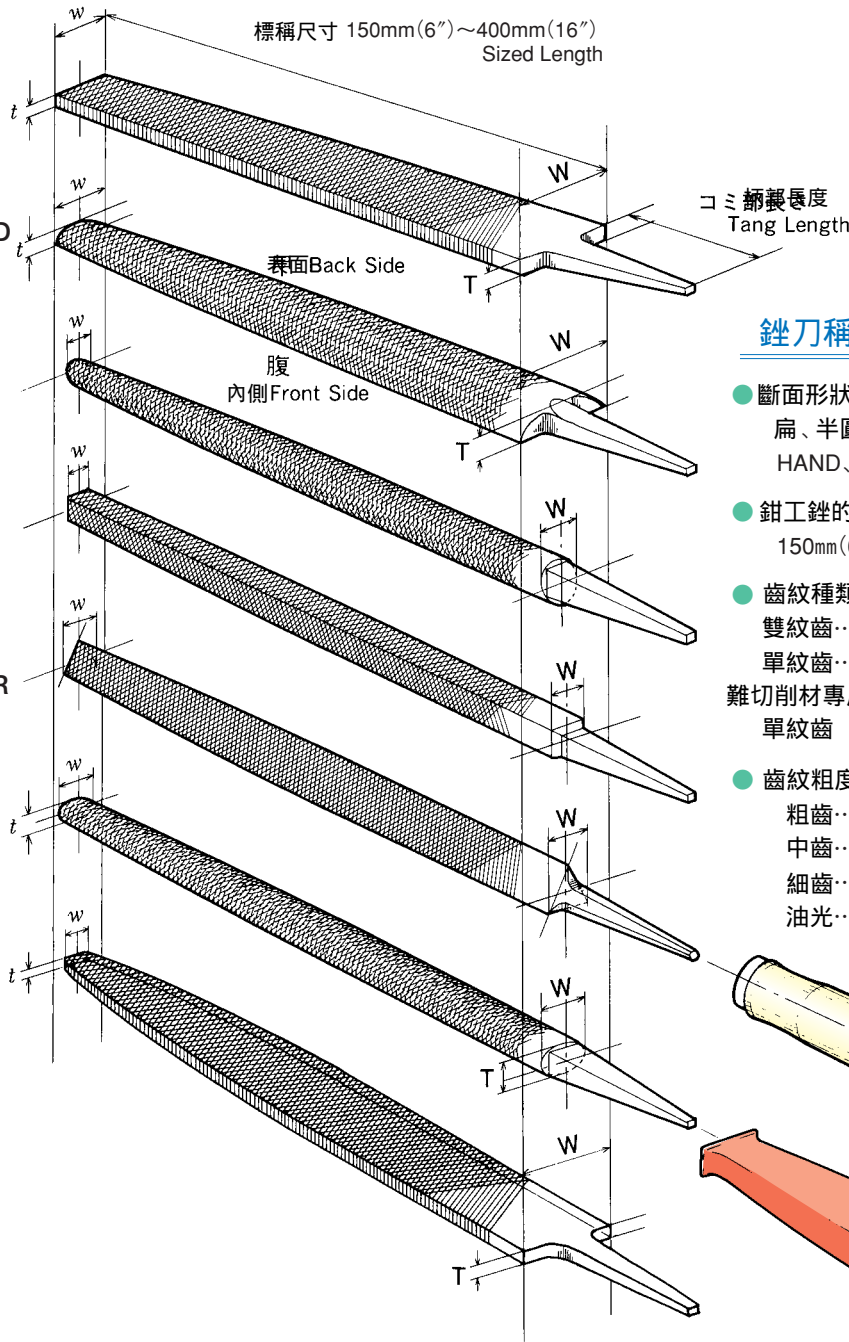

銼刀稱呼方法

- 斷面形狀 Shapes
扁、半圓、圓等
HAND、HALF ROUND、ROUND、etc.
- 鉗工銼的標稱尺寸 Sized Length
150mm(6")~400mm(16")
- 齒紋種類 Cutting Type
雙紋齒……………W-cut (Double)
單紋齒……………S-cut (Single)
難切削材專用齒 …Tri-cut
單紋齒 ……Uni-cut
- 齒紋粗度 Cutting No.
粗齒……………Bastard ◆
中齒……………Second ◆
細齒……………Smooth ◆
油光……………Dead Smooth ◆

900
木柄
Wooden Handle

901
塑料柄
Plastics Handle

齒紋粗度表 CUTTING No. TABLE

No. $\frac{1}{1\text{cm}}$ $\pm 10\%$ allowance

INCH		mm		荒目 ◆ cuts/cm	中目 ◆ cuts/cm	細目 ◆ cuts/cm	油目 ◆ cuts/cm	難切削材專用齒 cuts/cm	單紋齒 cuts/cm			
				Bastard	Second	Smooth	Dead Smooth	Tri-cut	Uni-cut			
6	150		12		16		25		38		13	—
8	200		10		14		22		34		12	
10	250		9		12		19		30		11	—
12	300		8		10		17		26	(10)	—	—
14	350		7		9		15		23	—	—	—
16	400		6		8		14	—	—	—	—	—

規格表 STANDARD TABLE

011

扁 HAND	INCH		mm		W × T	w × t	mm	kg-doz	BOX pcs	CARTON pcs	ITEM NO.
	6	8	10	12	14	16					
	6	150	16 × 4	14 × 2.5	40	0.82	12	240	HI 150 **		
	8	200	21 × 5	19 × 3	50	1.72	6	168	HI 200 **		
	10	250	25 × 6	22 × 4	60	3.22	6	120	HI 250 **		
	12	300	30 × 7	26 × 5	70	5.50	6	60	HI 300 **		
	14	350	34 × 7.5	30 × 5.5	80	8.00	6	60	HI 350 **		
	16	400	36 × 8.5	32 × 6.5	90	11.24	6	24	HI 400 **		

012

半圓 HALF ROUND	INCH		mm		W × T	w × t	mm	kg-doz	BOX pcs	CARTON pcs	ITEM NO.
	6	8	10	12	14	16					
	6	150	16 × 4.5	8.5 × 3.3	40	0.74	12	240	HA 150 **		
	8	200	21 × 6	12 × 4.3	50	1.82	6	168	HA 200 **		
	10	250	25 × 7	15 × 5.5	60	3.00	6	120	HA 250 **		
	12	300	30 × 8.5	17 × 6.5	70	5.26	6	60	HA 300 **		
	14	350	34 × 10	19 × 6.8	80	8.12	6	60	HA 350 **		
	16	400	36 × 11	20 × 7	90	10.48	6	24	HA 400 **		

013

圓 ROUND	INCH		mm		W	w	mm	kg-doz	BOX pcs	CARTON pcs	ITEM NO.
	6	8	10	12	14	16					
	6	150	φ 6	φ 3.3	40	0.46	12	240	MA 150 **		
	8	200	φ 8	φ 4.2	50	1.00	6	168	MA 200 **		
	10	250	φ 10	φ 5.2	60	1.88	6	120	MA 250 **		
	12	300	φ 12	φ 6.5	70	3.32	6	60	MA 300 **		
	14	350	φ 15	φ 8	80	5.62	6	60	MA 350 **		
	16	400	φ 18	φ 10	90	9.60	6	24	MA 400 **		

014

方 SQUARE	INCH		mm		W	w	mm	kg-doz	BOX pcs	CARTON pcs	ITEM NO.
	6	8	10	12	14	16					
	6	150	6	3.3	40	0.56	12	240	KA 150 **		
	8	200	8	4.2	50	1.20	6	168	KA 200 **		
	10	250	10	5.2	60	2.26	6	120	KA 250 **		
	12	300	12	6.5	70	4.00	6	60	KA 300 **		
	14	350	15	8.5	80	7.08	6	60	KA 350 **		
	16	400	18	11	90	11.40	6	24	KA 400 **		

015

三角 TRI- ANGULAR	INCH		mm		W × T	w × t	mm	kg-doz	BOX pcs	CARTON pcs	ITEM NO.
	6	8	10	12	14	(16)					
	6	150	12	7	40	1.10	12	240	SA 150 **		
	8	200	15	8.5	50	2.08	6	168	SA 200 **		
	10	250	17	10	60	3.24	6	120	SA 250 **		
	12	300	20	12	70	5.28	6	60	SA 300 **		
	14	350	22	13	80	7.14	6	60	SA 350 **		
	(16)	(400)	(25)	(14)	(90)	(10.24)	(6)	(24)	(SA 400 **)		

018

橢圓 OVAL	INCH		mm		W × T	w × t	mm	kg-doz	BOX pcs	CARTON pcs	ITEM NO.
	6	8	10	12	14						
	6	150	10 × 5.5	6.5 × 3.6	40	0.72	12	240	DE 150 **		
	8	200	12 × 8	7.8 × 5.2	50	1.05	6	168	DE 200 **		
	10	250	15 × 10	9.8 × 6.5	60	2.20	6	120	DE 250 **		
	12	300	18 × 12	12 × 8	70	3.90	6	60	DE 300 **		
	14	350	20 × 15	14 × 10	80	6.35	6	60	DE 350 **		

017

尖扁 FLAT	INCH		mm		W × T	w × t	mm	kg-doz	BOX pcs	CARTON pcs	ITEM NO.
	6	8	10	12	14	16					
	6	150	16 × 4	12 × 2.5	40	0.76	12	240	SH 150 **		
	8	200	21 × 4.5	17 × 3	50	1.54	6	168	SH 200 **		
	10	250	25 × 5.5	20 × 4	60	2.72	6	120	SH 250 **		
	12	300	30 × 6.5	24 × 5	70	4.80	6	60	SH 300 **		
	14	350	34 × 7.5	28 × 5.5	80	7.60	6	60	SH 350 **		
	16	400	36 × 8.5	30 × 6.5	90	10.90	6	24	SH 400 **		



手柄

900

TYPE	外形尺寸 Size	內孔直徑 Hole Size	kg-box	BOX pcs	ITEM NO.
木柄 Wooden Handle	小(S) φ 23 × 100	Flexible	1.2	50	ME 900S
	中(M) φ 25 × 115		1.6	50	ME 900M
	大(L) φ 27 × 135		1.3	30	ME 900L
	款(LL) φ 30 × 150		0.7	10	ME 900LL
塑膠柄 Plastics Handle	小(S)	φ 4.7	1.3	50	PE 901S
	中(M) 30 × 1.7 × 105	φ 6.3			PE 901M
	大(L)	φ 7.8			PE 901L

901

ITEM No. ** assorted

	粗齒 Bastard	中齒 Second	細齒 Smooth	油光 Dead Smooth	鑿切專用齒 Tri-cut	單紋齒 Uni-cut
雙紋齒 W-cut	01	02	03	04	05	15
單紋齒 S-cut	11	12	13	—		

<ITEM No.例> 鉗工銼扁150mm中齒 : HI15002

<ITEM No.例> ENGINEER'S FILE HAND 150mm Second

: HI15002