

### ■用途

- 滑雪底板和金屬稜邊的修整。

■Use : For repairing to sharpen SKI-edge, and to modify SKI-plates.

## 平扁型銼刀 HAND-TYPE SKI FILES

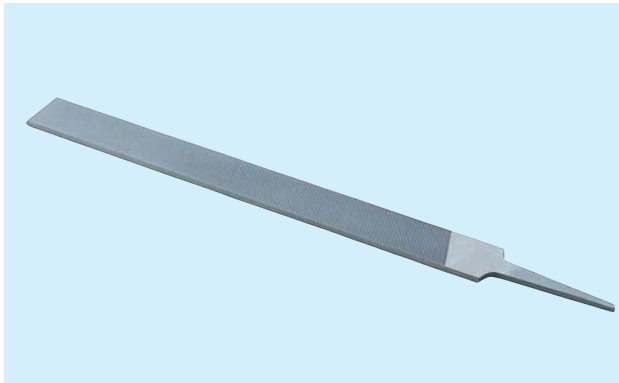

規格表 STANDARD TABLE

mm	W × T mm	kg-doz	齒紋粗度 (cuts/cm) Teeth Number	ITEM No.
150	15 × 2.5	0.60	中齒 14	SK 11
200	20 × 3.5	1.50	中齒 12.5	SK 12
250	24.5 × 4.5	2.52	中齒 10.5	SK 13
300	28 × 5.0	3.30	粗齒 8	SK 14
滲陶瓷 VC coating				
200	20 × 3.5	1.50	中齒 12.5	SK 15
250	24.5 × 4.0	2.52	中齒 10.5	SK 16

## 齒型銼刀 SQUARE SKI FILES

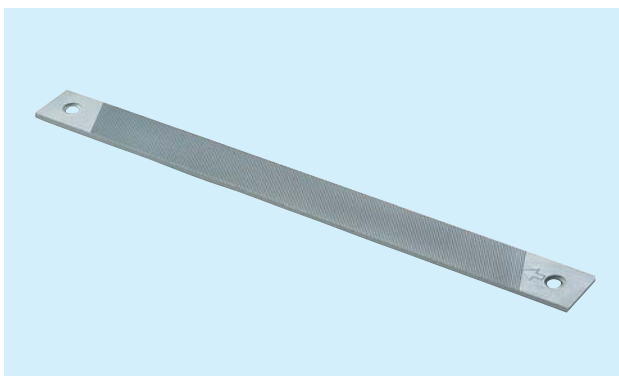

規格表 STANDARD TABLE

mm	mm	W × T mm	kg-doz	齒紋粗度 (cuts/cm) Teeth Number	ITEM No.
180	155	15 × 2.5	0.55	中齒 14	SK 21
200	無孔 (Non)	20 × 4.0	1.30	細齒 19.5	SK 22
230	205	20 × 3.5	1.32	中齒 12.5	SK 23
280	250	25 × 4.5	2.44	中齒 10.5	SK 24
330	300	28 × 5.0	4.38	粗齒 8	SK 25
355	325	34 × 5.0	4.94	粗齒 8	SK 26

## 滑雪板用銼片 SPARE SKI FILES

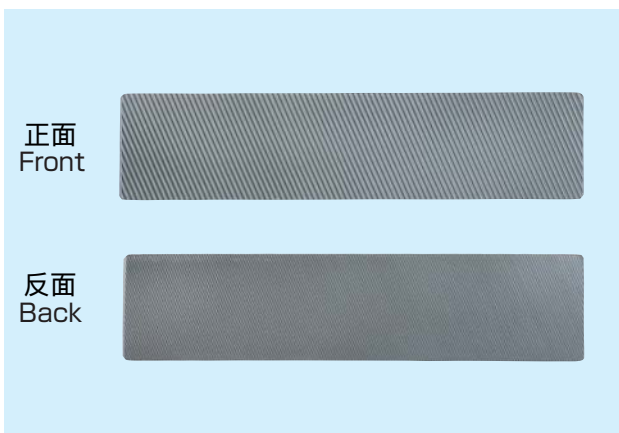

### ■用途

- 一面是粗加工，另一面是精加工用。
- 用於磨具的替刃。

■Use : A first finishing front on one side, and a final finishing (Back) on another one.  
Used in a changeable blade.

規格表 STANDARD TABLE

mm	W × T mm	kg-doz	齒紋粗度 (cuts/cm) Teeth Number	ITEM No.
60	28 × 4.5	0.78	粗齒 8    細齒 14	SK 31
80	28 × 4.5	1.02	粗齒 8    細齒 14	SK 32
120	28 × 4.5	1.56	粗齒 8    細齒 14	SK 33

## 小型滑雪銼 MINI SKI FILES

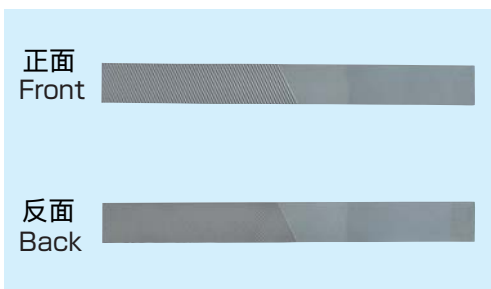

### ■用途

- 一面是粗加工，另一面是精加工用。

■Use : Two different cuts each side.

規格表 STANDARD TABLE

mm	mm	W × T mm	kg-doz	齒紋粗度 (cuts/cm) Teeth Number	ITEM No.
150	70	16 × 3.5	0.66	粗齒 8    中齒 13	SK 41

禮品&業餘愛好 GIFT & HOBBY

446

■用途

●禮品，業餘愛好，野外露營，釣魚等作為攜帶便利的室外工具使用。

■Use : For GIFT, HOBBY and OUTDOOR working.



ITEM No. TDUS1BU

釣具削刀 (固定型) S1  
DIAMOND SHARPENER (Blue Grip)  
(SOLID TYPE)



釣具削刀 (折疊型) G2  
DIAMOND SHARPENER (RED or BLACK Grip)  
(JACKKNIFE TYPE)



金剛石指甲銼 (附套)  
NAIL DIAMOND FILE

■用途 Use



釣鉤的刃部研磨，請使用#600面  
#600 face for FISHHOOK

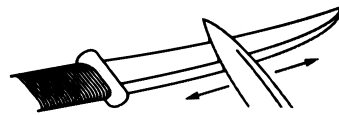

刀的刃部研磨，請使用#300面  
#300 face for KNIFE

■用途 Use



銼刀刷 BRUSH FOR FILES

970



規格表 STANDARD TABLE

TYPE	mm			kg-1p	ITEM NO.
小 (S)	215	80	25	0.06	BRS 215
中 (M)	225	80	40	0.10	BRS 225

皮革尖鑽 AWL

940



■特長

- 經油冷淬火處理，有堅韌硬度，經光澤塗層處理。
- 尖端部可穿線。

■用途

- 木柄為工業上使用。
- 塑膠柄為事務上使用。
- H類型 (有孔) 可穿繩子。

■Material : SKS-8, hardened by oil-quenching.

Cr plating.  
Usable as a scriber, convenient in both office and factory.

ITEM No. \* \* assorted

	S-Type 無孔 Solid	H-Type 有孔 with a hole
*	S	H

規格表 STANDARD TABLE

DIMENSION	mm		W mm	BOX pcs	kg-20pcs	ITEM NO.
	A	B				
木柄 Wooden Handle	100A	85B	φ3.2	20	0.37	ALW 100*
	150A					0.45
塑膠柄 Plastics Handle	100A	85B	φ3.2	20	0.59	ALP 100*
	150A					0.65





樂器製作用銼 STEELFILESFORMUSICINSTRUMENTS



磨刀棒

SHARPENING STEEL

835

■ 銼身經磁化處理，切屑粉不會散落。Magnetized!!

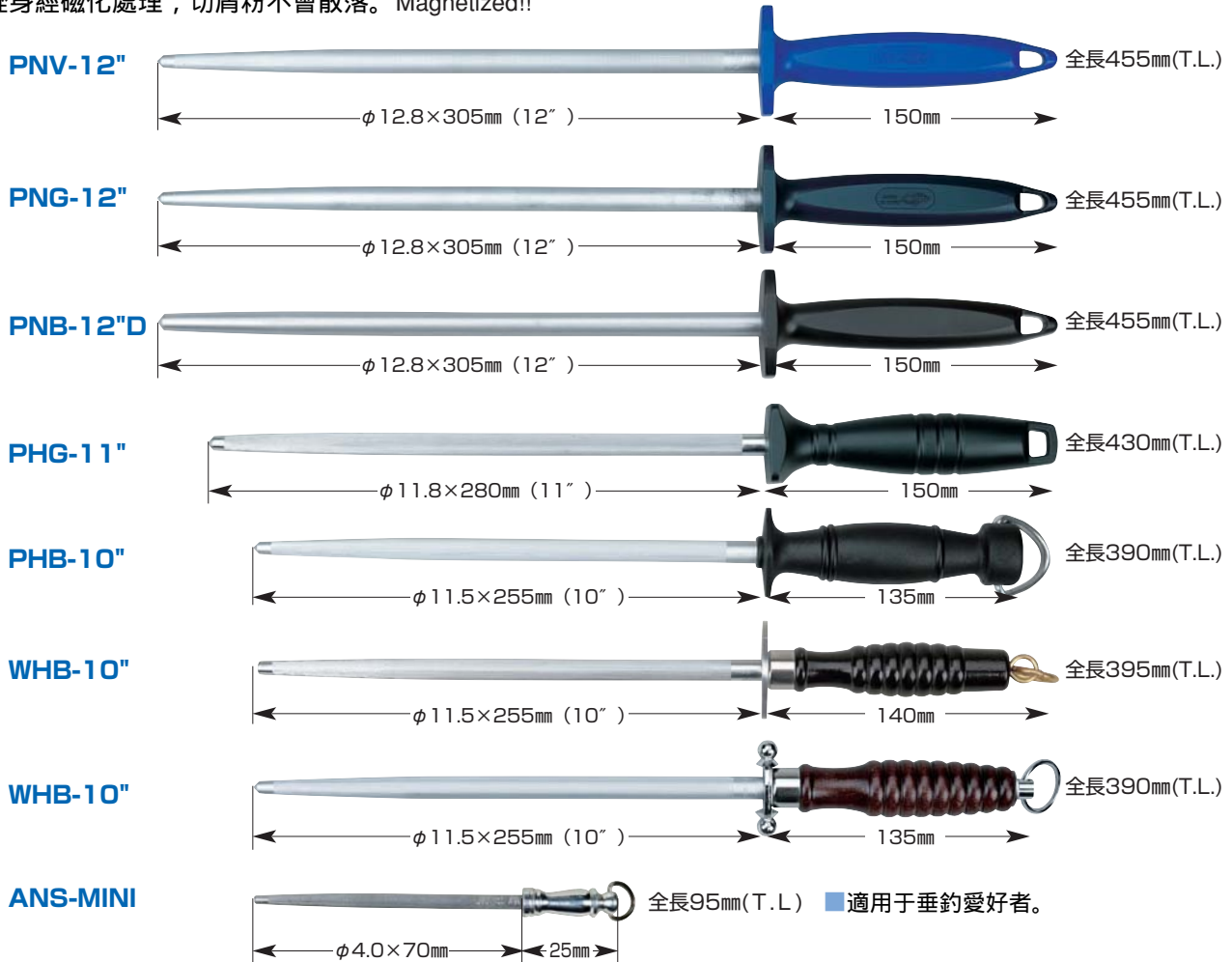

■ 使用方法 (其1) How to use (example 1)

- ① 用布等擦淨菜刀上的汗跡。
- ② 左手持磨刀棒，右手持菜刀，把菜刀在磨刀棒上左右交互磨研。  
 (研磨角度約20° -45°左右)
- ③ 從刀刃部的下端到前端，依次用磨刀棒研磨。(參照圖2-1, 2-2)
- ④ 重複該動作4-5次。
- ⑤ 測試，可切削蔬果，若仍不鋒利，可重複②-④的動作。  
 (鋒利的刀刃切洋蔥時眼睛不會刺痛)

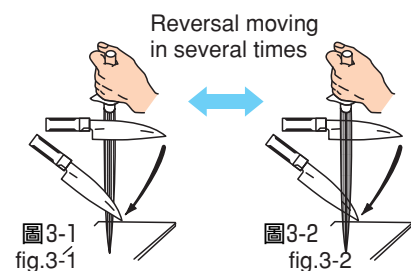
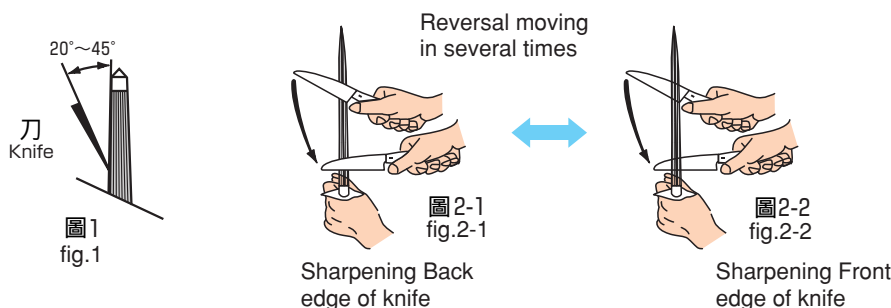

■ 使用方法 (其2) How to use (example 2)

- ② 把磨刀棒直立在平坦處修整刀刃。使用方法請參照(圖3-1, 圖3-2)。  
 (研磨角度根據刃物形狀約20° -45°左右。)(參照圖1)  
 ※①、③ - ⑤的操作方法同使用方法(其1)。

■ 使用注意

- 用布除去磨刀棒上粘附的鐵粉，保存在乾燥處。
- 注意刀，菜刀的刃部不要傷到手。
- 本製品用於刃部的修整，刀刃卷起時請用磨刀石。

■ caution !

- Not to cut your hands during sharpening knives.
- After sharpening knives, please wipe off steel powder magnetized on the sharpening steel by cloth and keep it dry.

磨刀棒

### 定制產品 SPECIAL ORDER

999

- 這裏舉例的是根據定單定制的銼刀。
- Any other type can be made at your request.

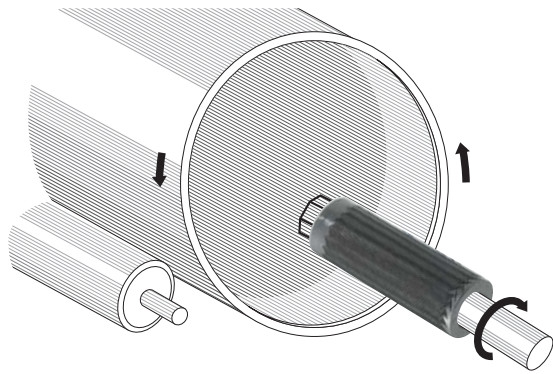

去除大口徑鋼管內的飛邊用的旋轉銼刀。  
ROTARY FILE for the inner trimming  
on the side face of a large pipe.

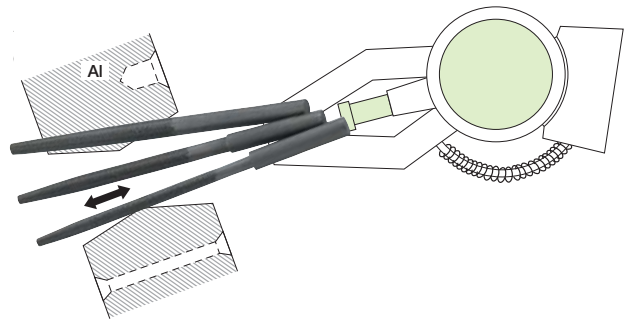

去除鋁型腔飛邊的銼。  
(裝置在機械手上使用)  
TRIMMING FILE  
for AI Die Casting work (wheel) .



舟型 SHIP-type  
曲型 CRANK-type

專業鐵工銼  
PRO-TYPE (ENGINEER'S FILE)



齒紋修整工具  
SCREW THREADS TOOL (OUTER)

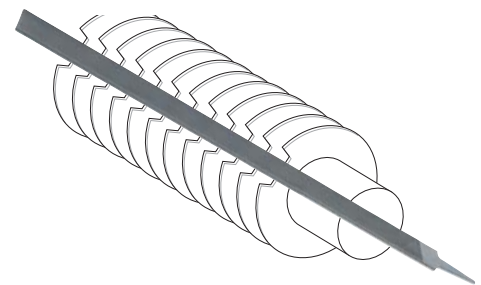

槽銼  
Slotting Files  
Max. length 450mm  
加工工件附窄槽。



氣動工具規格  
By AIR ACTING TOOL

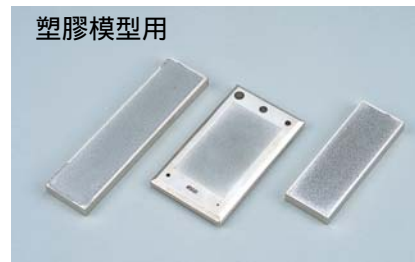

塑膠模型用  
磨刀石類型  
PLINTH type



橢圓型  
OVAL type