



## DIAMOND FILES



■ 用Ni电极沉积法固定金剛石顆粒。粘合力，研削度和耐磨性能得到提高。

■ 用途

● 使用于陶瓷，超硬金属，锻件等高硬度材料。

■ 使用注意

- 轻轻接触被切削件便能够充分研削。
- 湿式研削也有效，请加入少量油后使用。

■ Use : Please use it after dropping a little of oil on the working point.

Diamond Grids are fixed by Ni-plating process. Especially it's very available for the very high hardened materials modify, i.e. Ceramics, Hard-Metals, hardened steel etc..

### S類型 (金剛石粒度#200) S-TYPE (DIAMOND GRID NO.#200) 411

#### 規格表 STANDARD TABLE



"Precision Needle" TYPE

RED-GRIP

DIMEN-SION	DIMEN-SION			套裝 SET (每種形狀1支)	扁 HAND W × T mm	半圓 HALF ROUND W × T mm	圓 ROUND W mm	方 SQUARE W mm	三角 TRIANGULAR W mm
	TYPE	L mm	φ mm						
S-5	200L	70 ℓ	φ4.0A	—	8.0 × 2.0	7.0 × 2.5	φ4.0	3.5	5.0
	kg-1set	0.14			0.15	0.15	0.14	0.13	0.14
	No./1set	5 (each 1)			5	5	5	5	5
	ITEM No.	DSST 0520			DSHI 0520	DSHA 0520	DSMA 0520	DSKA 0520	DSSA 0520
S-8	180L	60 ℓ	φ3.5A	—	6.5 × 1.5	6.0 × 2.0	φ3.5	3.0	4.3
	kg-1set	0.11			0.12	0.12	0.11	0.11	0.11
	No./1set	5 (each 1)			5	5	5	5	5
	ITEM No.	DSST 0820			DSHI 0820	DSHA 0820	DSMA 0820	DSKA 0820	DSSA 0820
S-10	170L	50 ℓ	φ3.0A	—	5.8 × 1.1	5.5 × 1.5	φ3.0	2.7	3.8
	kg-1set	0.09			0.10	0.09	0.09	0.09	0.09
	No./1set	5 (each 1)			5	5	5	5	5
	ITEM No.	DSST 1020			DSHI 1020	DSHA 1020	DSMA 1020	DSKA 1020	DSSA 1020
S-12	170L	40 ℓ	φ2.5A	—	5.0 × 1.0	4.6 × 1.4	φ2.5	2.2	3.0
	kg-1set	0.08			0.08	0.08	0.08	0.08	0.08
	No./1set	5 (each 1)			5	5	5	5	5
	ITEM No.	DSST 1220			DSHI 1220	DSHA 1220	DSMA 1220	DSKA 1220	DSSA 1220

● #200以為都可以對應加工。

S-10 平 ■ #400 DSHI 1040 ■ #600 DSHI 1060  
S-12 平 ■ #400 DSHI 1240 ■ #600 DSHI 1260

### K類型 (金剛石粒度#150) K-TYPE (DIAMOND GRID NO.#150) 421

#### 規格表 STANDARD TABLE



"Die Sinker's" TYPE

BLUE-GRIP

DIMEN-SION	DIMEN-SION			套裝 SET (每種形狀1支)	扁 HAND W × T mm	半圓 HALF ROUND W × T mm	圓 ROUND W mm	方 SQUARE W mm	三角 TRIANGULAR W mm
	TYPE	L mm	ℓ						
K-5	215L	80 ℓ	—	—	11.0 × 3.5	12.0 × 3.8	φ5.5	5.5	9.0
	kg-1set	0.30			0.35	0.31	0.25	0.27	0.30
	No./1set	5 (each 1)			5	5	5	5	5
	ITEM No.	DKST 0510			DKHI 0510	DKHA 0510	DKMA 0510	DKKA 0510	DKSA 0510
K-8	200L	50 ℓ	—	—	9.0 × 3.0	9.5 × 3.0	φ4.3	4.3	7.5
	kg-1set	0.22			0.26	0.14	0.17	0.18	0.23
	No./1set	5 (each 1)			5	5	5	5	5
	ITEM No.	DKST 0810			DKHI 0810	DKHA 0810	DKMA 0810	DKKA 0810	DKSA 0810
K-10	185L	50 ℓ	—	—	7.0 × 2.5	7.3 × 2.5	φ3.2	3.2	6.0
	kg-1set	0.15			0.18	0.17	0.12	0.12	0.15
	No./1set	5 (each 1)			5	5	5	5	5
	ITEM No.	DKST 1010			DKHI 1010	DKHA 1010	DKMA 1010	DKKA 1010	DKSA 1010
K-12	170L	50 ℓ	—	—	4.0 × 2.0	4.2 × 2.0	φ2.5	2.5	4.0
	kg-1set	0.09			0.09	0.09	0.08	0.09	0.09
	No./1set	5 (each 1)			5	5	5	5	5
	ITEM No.	DKST 1210			DKHI 1210	DKHA 1210	DKMA 1210	DKKA 1210	DKSA 1210

● 能對應 50 ℓ ~ 100 ℓ 的電鍍加工。

K-5 平 ■ #150(100 ℓ) DKHI 0510(100)  
K-5 平 ■ #200(80 ℓ) DKHI 0520(80) (100 ℓ) DKHI 0520(100)



各種特殊金剛石銼

■特長

- 形狀，尺寸，金剛石粒度，金剛石長度等一應俱備。能應對各種作業。
- 還能根據客戶要求定制特殊形狀的金剛石銼。

■金剛石粒度

- 根據把手顏色的不同容易識別作業中金剛石的粒度。

■Use : Various kinds of SHAPES, DIMENSIONS and DIAMOND GRID NUMBERS(#) are combined to polish the surfaces of the hardened Metals and Ceramics in works. Furthermore ,TSUBOSAN accepts the customer's special order with a will. According to each difference of Grip Color, a worker can distinguish each roughness of Diamond File during his work.

	紫 (PURPLE)	# 100	
	藍 (BLUE)	# 150	
	紅 (RED)	# 200	
	綠 (GREEN)	# 300	
	黃 (YELLOW)	# 400	
	黑 (BLACK)	# 600	

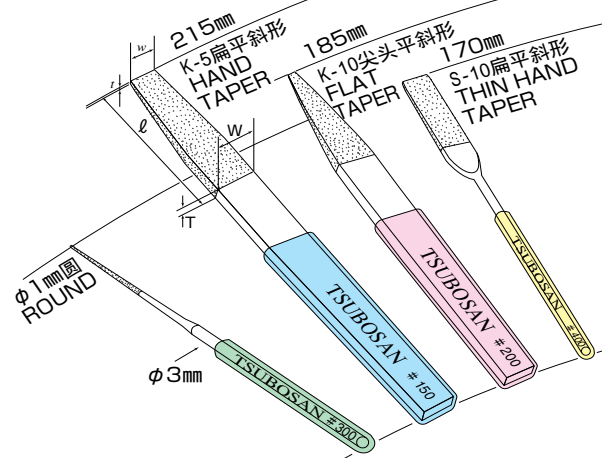
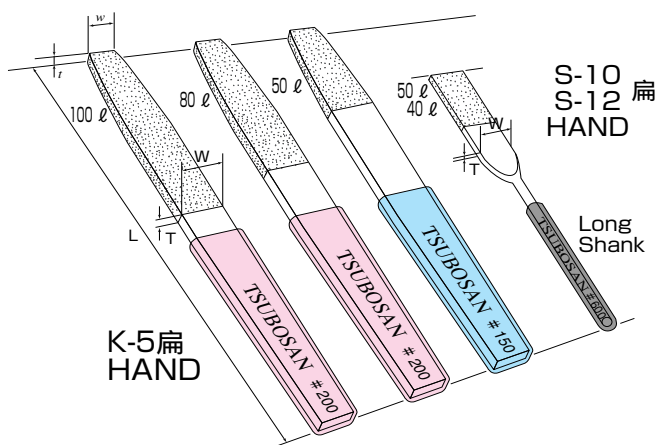

金剛石平斜銼

DIAMOND TAPERED FORM

426

規格表 STANDARD TABLE

DIMENSION		L		W × T mm	w × t mm	BOX pcs	kg-5 pcs	ITEM No.				
		L	ℓ mm					#150	#200	#300	#400	#600
K-5	扁平斜形 HAND TAPER	215	50	11.0×2.0	10.0×0.9	5	0.26	DKHI051T(50)	—	—	—	—
		215	80	11.0×3.0	10.0×0.9	5	0.26	DKHI051T(80)	—	—	—	—
K-8	扁平斜形 HAND TAPER	200	50	9.0×2.5	8.0×0.7	5	0.19	DKHI081T	DKHI082T	—	—	—
K-10	扁平斜形 HAND TAPER	185	50	7.0×1.8	6.5×0.7	5	0.12	DKHI101T	DKHI102T	—	DKHI104T	DKHI106T
	尖頭平斜形 FLAT TAPER	185	50	7.0×2.0	1.5×0.6	5	0.11	—	DKSH102T	—	—	—
K-12	扁平斜形 HAND TAPER	170	50	4.0×1.8	3.7×0.7	5	0.06	DKHI121T	DKHI122T	—	DKHI124T	DKHI126T
	尖頭平斜形 FLAT TAPER	170	50	4.0×1.4	1.5×0.6	5	0.06	—	DKSH122T	—	DKSH124T	DKSH126T
極細扁平斜形 VERY THIN HAND TAPER		170	50	2.5×1.3	2.0×0.4	5	0.02	—	DGHI122T	—	—	—

金剛石薄平銼

DIAMOND THIN HAND FORM

427

規格表 STANDARD TABLE

DIMENSION		L		W × T mm	w × t mm	BOX pcs	kg-5 pcs	ITEM No.				
		L	ℓ mm					#150	#200	#300	#400	#600
S-8	薄平 THIN HAND	180	50	6.5×0.8	—	5	0.12	—	DSHI082U	DSHI083U	—	—
	薄平 THIN HAND	170	40	5.8×1.1	—	5	0.06	DSHI101U	DSHI102U	DSHI103U	—	—
S-10	0.5mm 薄平 0.5mm THIN HAND	170	40	5.8×0.5	—	5	0.06	—	DSHI102U(0.5)	—	DSHI104U(0.5)	—
	薄平斜 THIN HAND TAPER	170	30	5.8×0.7	5.8×0.4	5	0.06	—	DHI102TU	DHI103TU	—	—
極細平 VERY THIN HAND DITCH		170	50	2.5×1.3	—	5	0.02	—	DGHI122U	—	—	—

金剛石銼

### 5 金剛石銼

#### 5" DIAMOND FILES

435



尺寸150mm

#### ■特長

- 與K-5類型相比比較厚，200mm長度比較全長及電極沉積長度短，能方便的收納進工具箱中。
- 銼身與柄部呈一體狀，使用相當方便。

■Use : This is the 5" DIAMOND FILE with a soft grip, regarding to the handy convenience for a file working, and this total length (215mm) FILE can be settled in a tool box easily.

#### 規格表 STANDARD TABLE

TYPE	DIMENSION		W × T mm	BOX pcs	kg-10pcs	ITEM No.	
	L mm	ℓ mm				#200	
扁 HAND	215L	80 ℓ	16 × 4	10	1.0	TDHI520H	
半圓 HALF ROUND			16 × 4.5	10	0.83	TDHA520H	

### 平扁200mm ( 8 ) 類型 (金剛石粒度#200, #600) HAND200mm (DIAMOND GRID NO.#200, #600) 430



#### 規格表 STANDARD TABLE

DIMENSION		W × T mm	kg-1pcs	ITEM No.	
L mm	ℓ mm			#200	#600
200L	180 ℓ	21 × 5	0.2	DHI20020	DHI20060

#### ■特長

- 鉗工·扁200mm材料用電極沉積法鍍上金剛石，適用於寬平滑面的作業。

### 金剛石研具

#### DIAMOND LAPPER

470



照片為#200。(Photo: #200)

#### 規格表 STANDARD TABLE

DIMENSION		W × T mm	BOX pcs	kg-5pcs	ITEM No.	
L mm	ℓ mm				#150	#200
200L	50 ℓ	10 × 3	5	0.35	TDHIL10	TDHIL20

- Grid No. ■ #150 (BLUE GRIP)
- Grid No. ■ #200 (RED GRIP)

### 金剛石菱形銼

#### DIAMOND FEATHER EDGE SAW-FILES

445



#### ■特長

- 鋸齒修整時使用。在菱形銼的形材上用電極沉積法鍍上金剛石，能有效提高鋸齒的再生能力。

#### ■用途

- 適用於鋸齒再生，切割玻璃，鍛件，超硬金屬，陶瓷等材料的研削。

■Use : DIAMOND GRID # 300 are plated on FEATHER EDGE SAW FILES blank. It is easier and faster to sharpen the teeth of HAND SAW.

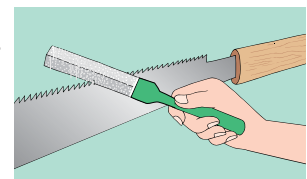

#### 規格表 STANDARD TABLE

TYPE	DIMENSION		W × T mm	BOX pcs	kg-10pcs	ITEM No.		
	L mm	ℓ mm				#150	#300	
DIA菱形銼 DIAMOND FILE-SAW	75mm (3")	155L	70 ℓ	17 × 2.3	10	0.31	—	TDRH 330H
	100mm (4")	180L	90 ℓ	20 × 3.0	10	0.51	TDRH 410H	TDRH 430H
	125mm (5")	215L	100 ℓ	25 × 3.5	10	0.78	—	TDRH 530H

# 金剛石異形銼

DIAMOND CRAFTSMAN

450

#200  
#400



**特長**

●線徑與S-10類型相同。適用於修整鍛模的底部，溝狀細微部分的作業。

**Use :** These bended Diamond RIFLOIRS are used for the Molding-Die works, especially pointed at the corners of bottom of the Molding-Dies.

**規格表 STANDARD TABLE**

L		7種套	扁 HAND	半圓 HALF ROUND	圓 ROUND	方 SQUARE	三角 TRIANGULAR	溝圓 HOOK ROUND	刀口 KNIFE
mm	A mm		25	40	25	25	25	25	40
170L	2.9A								
電鍍部分長度 PLATED LENGTH (mm)			25	40	25	25	25	25	40
BOX	pcs	7(each1)	7						
kg-7pcs		0.12	0.12						
ITEM No.	#200	TDST20J	TDHI20J	TDHA20J	TDMA20J	TDKA20J	TDSA20J	TDKM20J	TDKH20J
	#400	TDST40J	TDHI40J	TDHA40J	TDMA40J	TDKA40J	TDSA40J	TDKM40J	TDKH40J

# 金剛石線狀圓銼

DIAMOND LINE-ROUND

428

#200  
#300



**特長**

●金剛石電極沉積鍍層，直徑φ 1.0mm~φ 2.0mm(尖端有錐形)的極細類型。裝置粗柄容易操作性。適用於溝底洞穴加工。

**Use :** These Diamond Files like a needle have the diameter range of φ 1.0mm-φ 2.0mm in parallel (tapered to the top) with the bigger handle to use easily. To polish the bore hole.

**規格表 STANDARD TABLE**

DIMENSION		金剛石粒度 Grid No.	L		W mm	BOX pcs	kg-10pcs	ITEM No.
TYPE	ROUND		mm	φ				
1.0mm	圓 ROUND	#300	170L	50 ℓ	φ 1.0	10	0.10	DLMA 1030
1.2mm								DLMA 1230
1.5mm		#200						DLMA 1520
2.0mm								DLMA 2020

# 金剛石電動鋸用銼

DIAMOND ROUND CHAIN SAW-FILES

447

#300



**特長**

●修整電動鋸的刃部時使用。能有效進行電動鋸的刃部再生作業，提高使用壽命。

**Use :** These DIAMOND ROUND CHAIN SAW FILES are available to sharpen the teeth of Chain-Saw-Machine, with a speedy work and a long life.

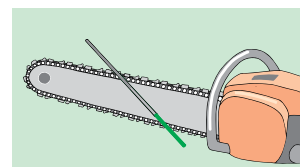

**規格表 STANDARD TABLE**

DIMENSION		L	W mm	BOX pcs	kg-10pcs	ITEM No.
TYPE	ROUND					
DIA電動鋸用銼 DIAMOND CHAINSAW FILE	φ 3.2mm (1/8")	220L	80 ℓ	10	0.14	TDMA3230
	φ 4.0mm (5/32")					TDMA4030
	φ 4.7mm (3/16")					TDMA4730

# 金剛石圓形銼

DIAMOND ROUND-TYPE(DIAMOND GRID NO.#400)

460

#400



**規格表 STANDARD TABLE**

DIMENSION		L	W mm	BOX pcs	kg-10pcs	ITEM No.			
TYPE	ROUND								
140L	50 ℓ	φ 1.2	φ 1.2	10	0.06	TD 03124			
						φ 1.5	10	0.07	TD 03154
						φ 2.0	10	0.08	TD 03204
						φ 2.5	10	0.11	TD 03254
						φ 3.0	10	0.14	TD 03304
						φ 3.5	10	0.16	TD 03354
φ 4.0	10	0.20	TD 03404						

金剛石銼

## 彈性竹杆金剛石銼 FLEX DIAMOND (Bamboo Stick) 440



### ■特長

- 因為銼身是竹制的，具有輕和彈性的性能。
- 尖端部分加工成錐形，柔軟性，銼削性，耐久性及操作性出色。
- 有#120，#200，#400，#800等規格。

■Use : By the way of the flexibility of its own bamboo stick, the top point of the stick with the bonded FLEX DIAMOND SHEET (No.442) can be utilized for a slender work, delicately.

### 規格表 STANDARD TABLE

DIMEN-SION TYPE	金剛石粒度 Grid No.	W		ITEM No.
		W	L	
直線型 STRAIGHT-Type	黃色/YELLOW #400	200L	10W	BHI 0840
		170L	6W	BHI 0740
200L		10W	BHIS 840	
170L		6W	BHIS 740	
6件套 6-PCS.SET		各一支，金剛石貼皮一張，竹軸一根。 Ins.+FLEX DIA+Bamboo Stick(blank)		BHIS T40

## 可彎金剛石薄型貼皮 FLEX DIAMOND SHEET 442

### ■特長

- 薄型貼皮背面為強力粘合膠。
- 根據不同尺寸，用裁紙刀，鐵皮剪等切割後粘貼本公司的竹軸（No.440）上使用。

■Use : Cut-able freely by scissors or knife. This FLEX DIAMOND SHEET attaches to a special adhesive on each reverse side.



### 規格表 STANDARD TABLE

DIMEN-SION TYPE	金剛石粒度 Grid No.	L × W mm	kg-10pcs	ITEM No.
可彎金剛石薄型貼皮 (竹軸用) FLEX DIA	黑色/BLACK #120	50 × 50	0.03	TDPA 12K
		50 × 100	0.06	TDPA 12N
	紅色/RED #200	50 × 50	0.03	TDPA 20K
		50 × 100	0.06	TDPA 20N
	黃色/YELLOW #400	50 × 50	0.03	TDPA 40K
		50 × 100	0.06	TDPA 40N
	白色/WHITE #800	50 × 50	0.03	TDPA 80K
		50 × 100	0.06	TDPA 80N

## 金剛石砂紙 DIAMOND SHEET 490



### 規格表 STANDARD TABLE

金剛石粒度 Grid No.	T	L × W mm	kg-10pcs	ITEM No.
#100	0.5T	50 × 100	0.055	TDPA 100
#200			0.045	TDPA 200
#300			0.040	TDPA 300
#400			0.035	TDPA 400
#600			0.032	TDPA 600

### ■特長

- 在0.5mm厚(T)的銅板上用電極沉積法鍍上金剛石。用剪刀，裁紙刀自由切割尺寸，用雙面膠或強力膠粘貼使用。

■Use : Cut-able freely by scissors or knife. This is bonded on any surface of tools by a chemical adhesive or a tape.

# 金剛石修整筆

## DIAMOND DRESSER

480



●端部鑽石尺寸為6種。  
Diamond grain size  
(1/3CT · 1/2CT · 3/4CT · 1CT · 1.5CT · 2CT)

### 規格表 STANDARD TABLE

mm	W mm	kg-1p	ITEM No.
100	φ10	0.06	TDD 10**
	φ11	0.07	TDD 11**
	φ12	0.09	TDD 12**

ITEM No. \*\* assorted

CT	1/3	1/2	3/4	1.0	1.5	2.0
**	01	02	03	04	05	06

(注) φ10mm 柄徑無1.5CT · 2.0CT。  
(\* ) The range of φ10mm shank is upto 1.0CT.

# 金剛石割磨片

## DIAMOND DISK SHARPENER

485

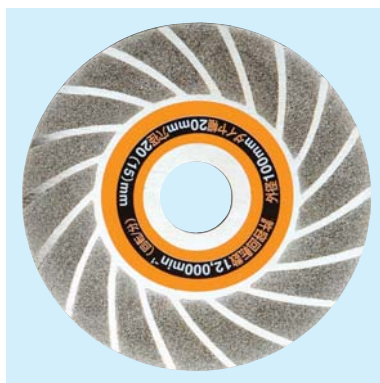

### 規格表 STANDARD TABLE

mm	mm	mm	kg-1p	ITEM No.
φ100W	20w	1.1T	0.07	TDE 100



圓盤鋸 (Disk Saw)

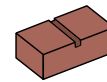

磚瓦 (Block)

### 用途

●適用於割草用圓盤鋸，刃物的再生研磨和磚，瓷磚等的切割用。

■Use : For sharpening CBN Hand Metal & Knives, or for facing & cutting off ceramic tile and brick block.

# 金剛石打孔鑽

## DIAMOND CORE DRILL

484

### 用途

●先將待打孔部位加入充分的水，把物件物牢靠固定後進行作業。

■Use : For holing work on ceramic tile and brick block. Used by the electric acting power tool, and worked on the fixed article tightly with cooling water supply.

### 規格表 STANDARD TABLE

ITEM No.	DCD 0300	DCD 0400	DCD 0500	DCD 0600	DCD 0800	DCD 1000
A mm	φ3	φ4	φ5	φ6	φ8	φ10
B mm	10	21	30	35	35	35
C mm	30	26	35	30	30	30
kg-1p	0.011	0.011	0.014	0.014	0.016	0.017



ITEM No.	DCD 1200	DCD 1500	DCD 1600	DCD 1800	DCD 2000	DCD 2200	DCD 2500	DCD 2600	DCD 2800	DCD 3000	DCD 3200	DCD 3500	DCD 3800	DCD 4000
A mm	φ12	φ15	φ16	φ18	φ20	φ22	φ25	φ26	φ28	φ30	φ32	φ35	φ38	φ40
kg-1p	0.027	0.033	0.034	0.040	0.044	0.046	0.054	0.060	0.060	0.061	0.075	0.075	0.083	0.085

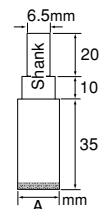

### 使用例

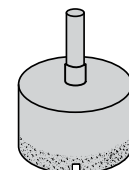

電鍍金剛石粒  
Plated Diamond Grid  
±3.5mm  
粒度#120  
Grid No.120

